

SEMINAR SUBJECTS

Distributed by:
Navair Inc &
Systems Solutions Group
<http://www.navair.com/>
<http://www.navair.com/catalog>
http://www.navair.com/solutions_group
Phone: :(905)565-1583
Toll Free: 1-800-668-7440

T-PASS™ EXPANDABLE CAVITY MULTICOUPLER SYSTEM

(PAT. NO. 4249147)

BY DANIEL P. KAEGBEIN
PRESIDENT AND CHIEF ENGINEER



THE FIRST NEW APPROACH IN 20 YEARS

THE T-PASSTM EXPANDABLE MULTICOUPLER

(AND OTHER DESIGNS)

Rev. 4/81

OBSTACLES TO EXPANDABILITY

The basic problem in constructing a simple and easily field expandable multicoupler system has been the physical constraints imposed upon the mechanical proximity and orientation of the channel filter elements or "cavities", so as to satisfy the transmission line wavelength requirements for proper impedance matching of all channels to a common antenna junction. These cavity filters are the bandpass type, which provide the high selectivity and broad isolation characteristics demanded of multi-channel systems. Highly selective filters are large by nature, and increased selectivity can only be obtained by increasing the size and/or number of cavities in the filter channel, compounding the mechanical interconnect problem.

Multiple wavelength cables must often be used in the antenna junction matching harness. In the common parallel bridging technique used, this adds to the transformation losses, increases the number of joints for intermod production, adds to the cost, and has no predictable and easily controlled pattern of channel matching, unless certain physical restrictions (and hence, electrical) are placed on the channel and total multicoupler construction.

EARLY ATTEMPTS AT EXPANDABILITY

Various methods have been used to obtain a degree of expandability. Concerning the common parallel bridging of channels, a complete mechanical package may be designed, consisting of a fixed number of channels, and fixed size and number of cavities in that channel. If, for instance, a six channel system is planned for ultimately, with one cavity per channel, a matching harness is provided to bridge six cavity filters. If only two channels (cavities) are initially supplied, the remaining four bridging cables may be terminated in a stub, simulating the missing cavity filters, or the transformation cables may be completely omitted from the seven-way junction, being attached as each succeeding channel is added.

Other approaches are worthy of note, as it will aid in understanding the significance of the T-Pass interconnection system. An expandable cavity multicoupler system has been constructed using the technique shown in U.S. Patent 3,124,768 and Canadian Patent 683741, issued in early 1964. It eliminates the physical problem of interconnecting multiple channels by removing the length sensitivity of "exterior" channel interconnect cables. A diagrammatic representation of this design is shown on page 5 of the attached system illustrations. Briefly the channel "independence" is a result of a channel notch filter tuned to the channel frequency, and positioned "electrically" on a section of the antenna thurline, an odd number of quarterwave lengths from the junction of the bandpass transformation cable with that section of thurline. This notch filter allows passage of all system frequencies along the antenna thurline except its own, which it causes to be passed into or out of, its tuned bandpass filter channel. Each one of these channels must incorporate this notch filter and its "tuned" section of antenna thurline. Subsequent sections of thurline "between" these channels are not length sensitive.

THE T-PASS EXPANDABLE CAVITY MULTICOUPLER SYSTEM

One other "antenna matching system" has been used, but undoubtedly on a limited basis, as it requires many critical length cables. In effect, it can be related to the expandable bandpass-plus-notch type filter channel, and what would be the make-up of the antenna thru-line if the channel notch filters were omitted. This approach is shown on page 6 of the attached system diagrams. The bottom end of the antenna thru-line is terminated in a short or open circuit, and each channel is "Tee" connected into the thru-line at a point of high impedance, via a channel "bridging" or transformer cable, allowing the channel to see only the 50 ohm antenna at that frequency. It is to be expected that a considerable degree of "cable pruning" will be required when frequencies are changed.

The parallel bridging of channels to a common junction and the variation, using the "Tee" tap into magic points on the thru-line, also suffers from bridging losses due to non-optimum transformer cable lengths. Since certain cables must be "averaged" in length to appear as a quarterwave or some multiple over a range of frequencies, the bridging loss will be lowest at the median design frequency and increase accordingly at frequencies above and below.

FIRST DESIGN IMPROVEMENTS: EMF CHANNELS

Our search for an improved expandable multicoupler design resulted in two new patented systems. The second approach, trademarked T-Pass, is the most novel, as it uses some transmission line structures which, to our knowledge, are unique to this application.

Our first approach was an improvement over the bandpass-notch-type channel, by eliminating the length sensitive cable in the antenna thru-line within the filter channel itself. A cavity notch filter was designed which produced a high impedance in series with the antenna thru-line. The bandpass "bridging" transformer cable then connected directly to the point at which the antenna thru-line entered the series high impedance notch filter; this junction being fixed and soldered internally under the series notch filter coupling assembly. This simplified construction and eliminated friction joints along the antenna thru-line which contribute to intermod generation.

The system is trademarked EMF channels, and still requires the additional notch filter to provide the channel independence required for easy expandability. Our ultimate goal in providing easy expandability without the use of this additional notch filter was realized in the T-Pass design.

T-PASS CHANNELS: THE ULTIMATE DESIGN

The heart of the T-Pass channel is the construction of the bandpass filter coupling mechanism which joins the channel to the main antenna thru-line. We have called this filter a T-Pass cavity, since it functions as an ordinary bandpass filter in terms of loss and selectivity characteristics, while also forming a Tee junction on the main antenna thru-line. There is no transformer cable required between the channel bandpass filter and the thru-line, as is required in all other designs to date. Therefore, these transformation losses due to cable dissipation and frequency sensitivity are eliminated.

THE T-PASS EXPANDABLE CAVITY MULTICOUPLER SYSTEM

The cables which interconnect the T-Pass channels are length sensitive, but can easily be determined from a cable cutting chart, once the channel frequencies are known. There are no "average" length cables interconnecting the channels, so accumulative losses due to "bandedge" errors are eliminated. The terminating stub is the only cable which is an average length for the system operating band, and due to the nature of the cable cutting procedure for antenna thurlines, cannot contribute to any cable length error in the cutting of these cables.

The first page of T-Pass diagrams show the construction of the T-Pass coupling assembly and how it functions as a bandpass loop when properly connected to an open circuited stub.

The second page of diagrams shows the principle of multiple channel stubbing, accomplished by interconnecting the T-Pass coupling assemblies with "resonant" cables, such that at each channel frequency, a short circuit is reflected to the J_2 connector of that T-Pass assembly. In this manner, many channels can be optimally connected to a common antenna terminal. Thruline interconnect cables are roughly one halfwave at VHF frequencies, and a fullwave at UHF. The physical cable length will be somewhat shorter, as the T-Pass loop provides some of the electrical length. No set frequency order of interconnection is required. However, so that the thruline cables tend to get longer instead of shorter (possibly too short for physical connection) it is recommended to place high channel frequencies at the stub of end of the thruline and proceed lower in frequency toward the antenna. For convenience in adding channels without re-ordering frequencies and cutting new cables, some variance can certainly be allowed.

The accuracy of the thruline cable length becomes more important for channels furthest from the terminating stub, as more multiple wavelengths are required. The electrical length of each T-Pass loop assembly is accurately controlled by construction jigs and by the calibration of the T-Pass loop capacitor, using a digital capacitance meter and sweep display showing return loss (impedance) data.

Individual channel losses will vary, depending on the number of cavity filters in each channel and their loss settings, the frequency separation between channels, and the total number of channels in the system.

The mechanics of a complete system design is a subject unto itself. However, the flexibility of the T-Pass channel expansion system can be seen by referring to the attached T-Pass Channel Design Table. Ferrite/Cavity Transmit channels, plus gain receive channels are readily constructed. Channels may be easily re-constructed, and will mount in standard 19" and 24" wide relay racks. Ceiling rafters have even been used as channel mounting rails.

Our Multicoupler System Sales Department can provide individual system designs when provided certain basic information. If predetermined system guidelines are followed, expanding a system can be as simple as ordering the correct pre-tuned T-Pass Channel and Thruline cable and mounting it in your rack, ready for operation.

CAVITY MULTICOUPLER DESIGNS

(PREVIOUS TECHNOLOGY)

I. STANDARD PARALLEL BRIDGING

- a) Simple star junction requires close proximity of junction cavities.

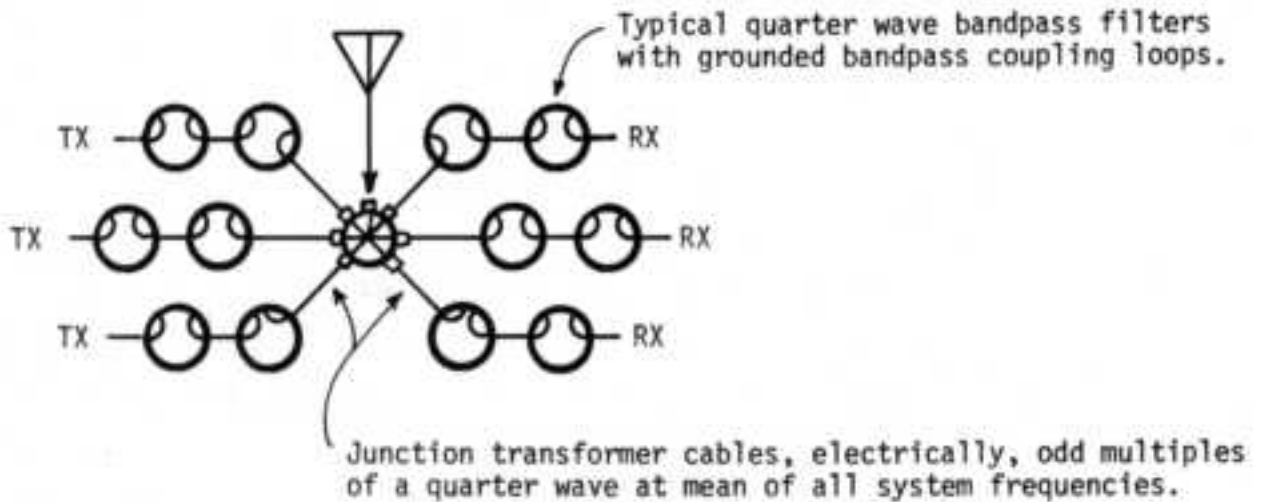

Number, size, and insertion loss of cavities is a function of channel frequency separation and isolation required between equipments.

- b) Multiple wavelength transformers to common antenna junction

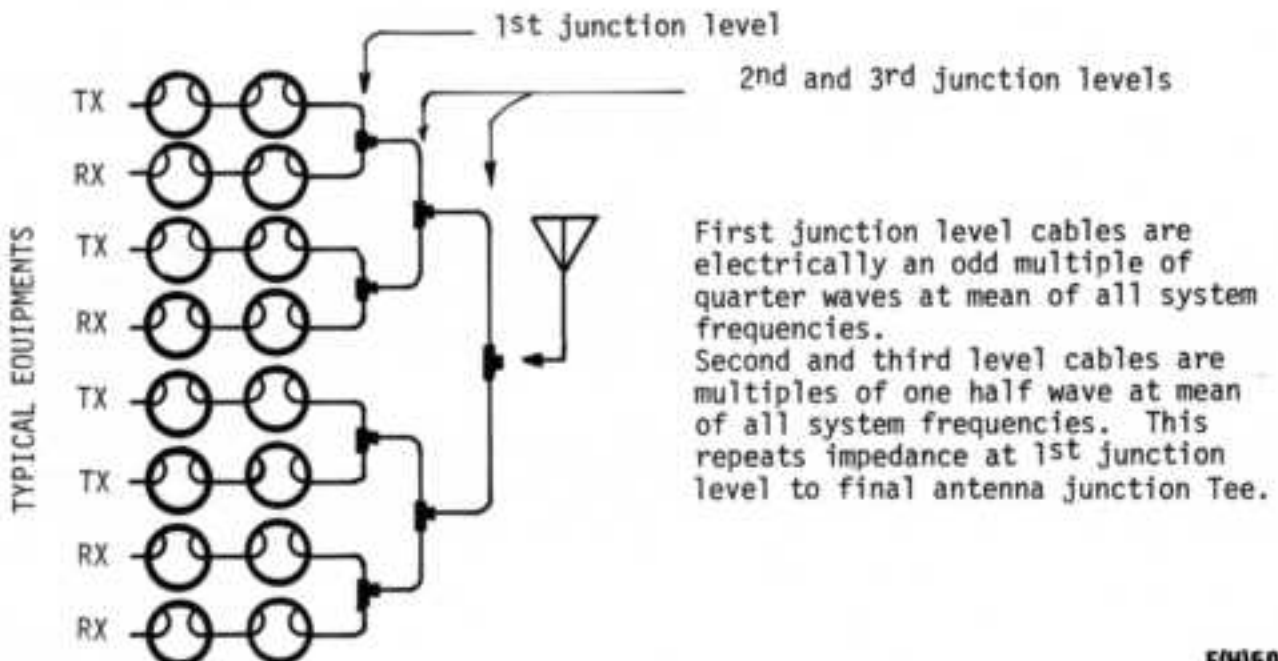

CAVITY MULTICOUPLER DESIGNS

(PREVIOUS TECHNOLOGY)

II. Expandable system under U.S. Patent 3,124,768 and Canadian Patent 683,741.

a) Basic channel construction

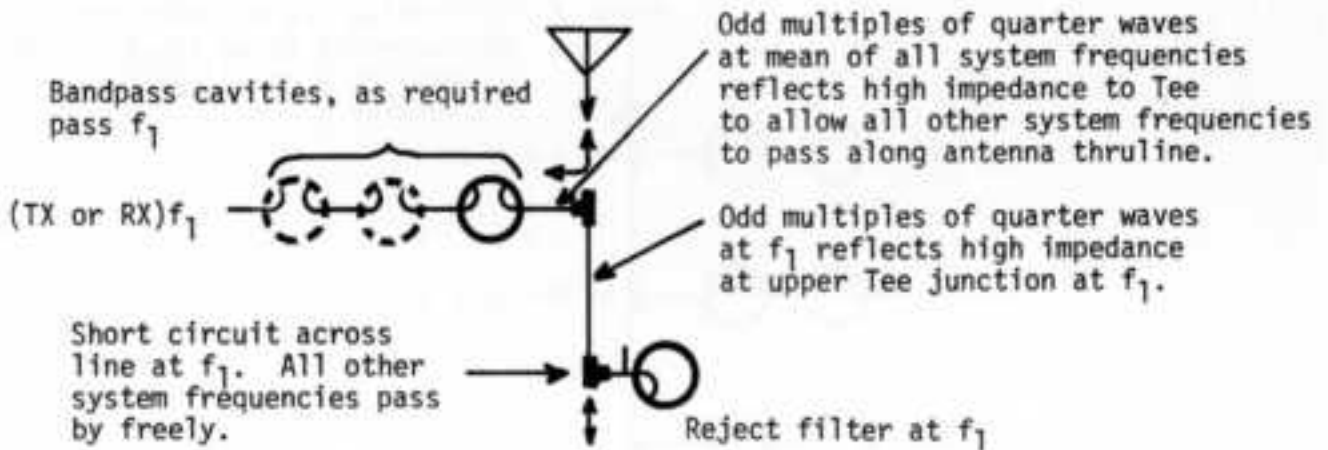

b) Typical cascade

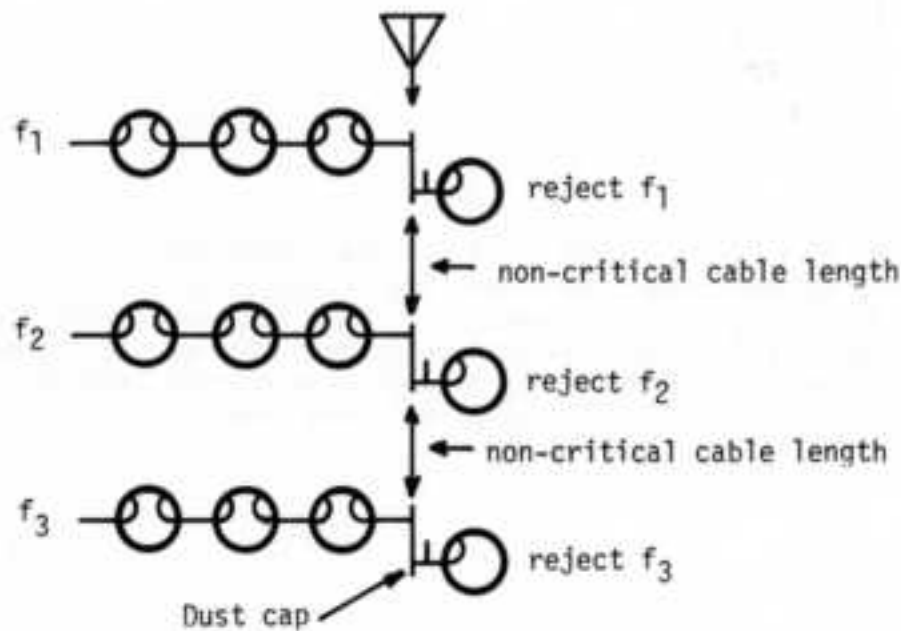

Frequency orientation may be specified, depending on broadness of passband above and below notch of reject filters.

CAVITY MULTICOUPLER DESIGNS

(PREVIOUS TECHNOLOGY)

III. Parallel bridging with "Tee Tapped" antenna thurline.

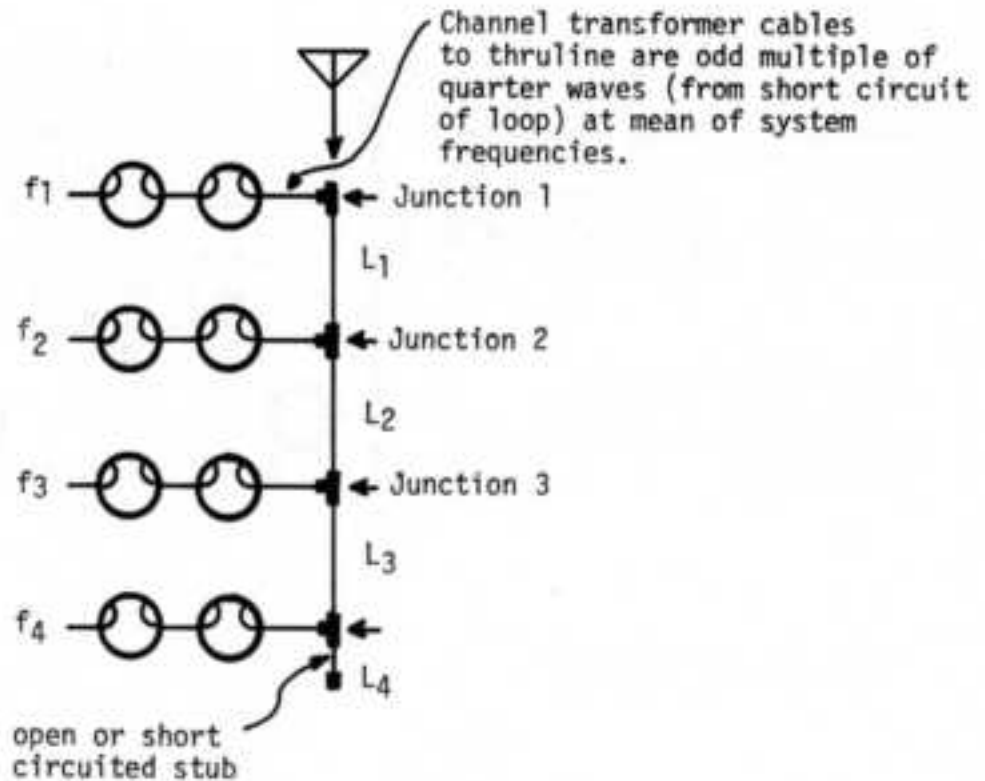

The lengths of L_1 thru L_4 are chosen so that where channel transformer cables connect into thurline at Junctions 1 thru 4, high impedances appear at frequencies f_1 thru f_4 respectively, looking down the thurline from that junction. This causes channel energy to flow up to the antenna, or down from antenna into the respective tuned channel, with relatively low loss.

IMPROVED CAVITY MULTICOUPLER DESIGN

" EMF " CHANNELS, FORERUNNER TO T-PASS
(TX RX SYSTEM PATENT NO. 4206428)

(Expandable Multicoupler Filter)

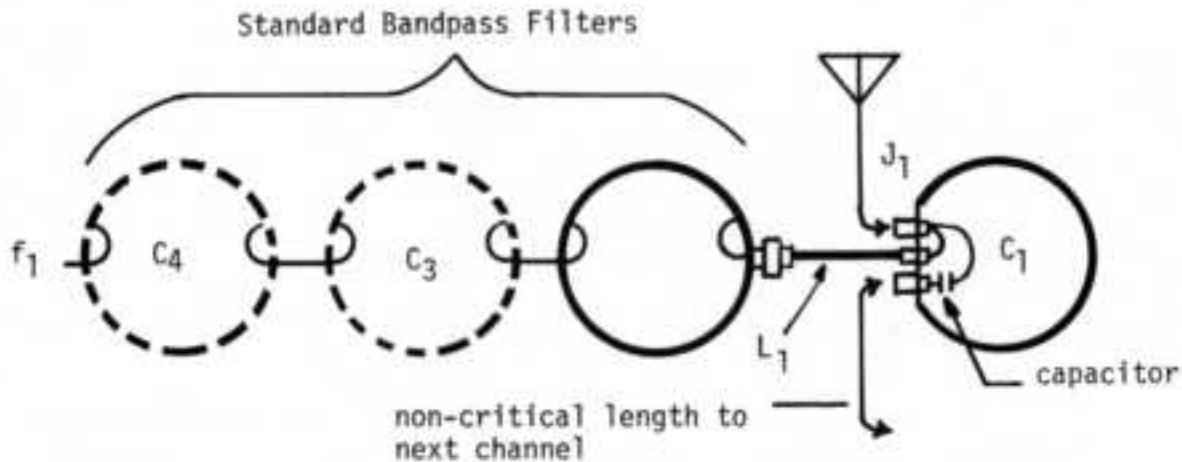

Cavity C_1 resonates on frequency f_1 and produces a series high impedance in the line between connectors J_1 and J_2 . Transformer cable L_1 is tapped into J_1 under the coupling plate assembly ahead of the high impedance, allowing energy at f_1 to flow freely between L_1 and J_1 . Cable L_2 is an odd multiple of quarter wave lengths (from loop ground in C_2) at the mean system frequency.

The capacitor in the non-grounded coupling assembly of C_1 is made from silver-plated loop strap and teflon tape, and broadly series resonant with the inductor. When C_1 is not resonant, energy will pass freely between J_1 and J_2 over a wide frequency band, symmetrically, above or below f_1 .

The series notch assembly of C_1 is constructed on a 1.75" Dia. plate on top of the cavity, and is rotatable, allowing variable coupling and control of depth of the series high impedance notch.

IV.

b) Typical "EMF" channel cascade

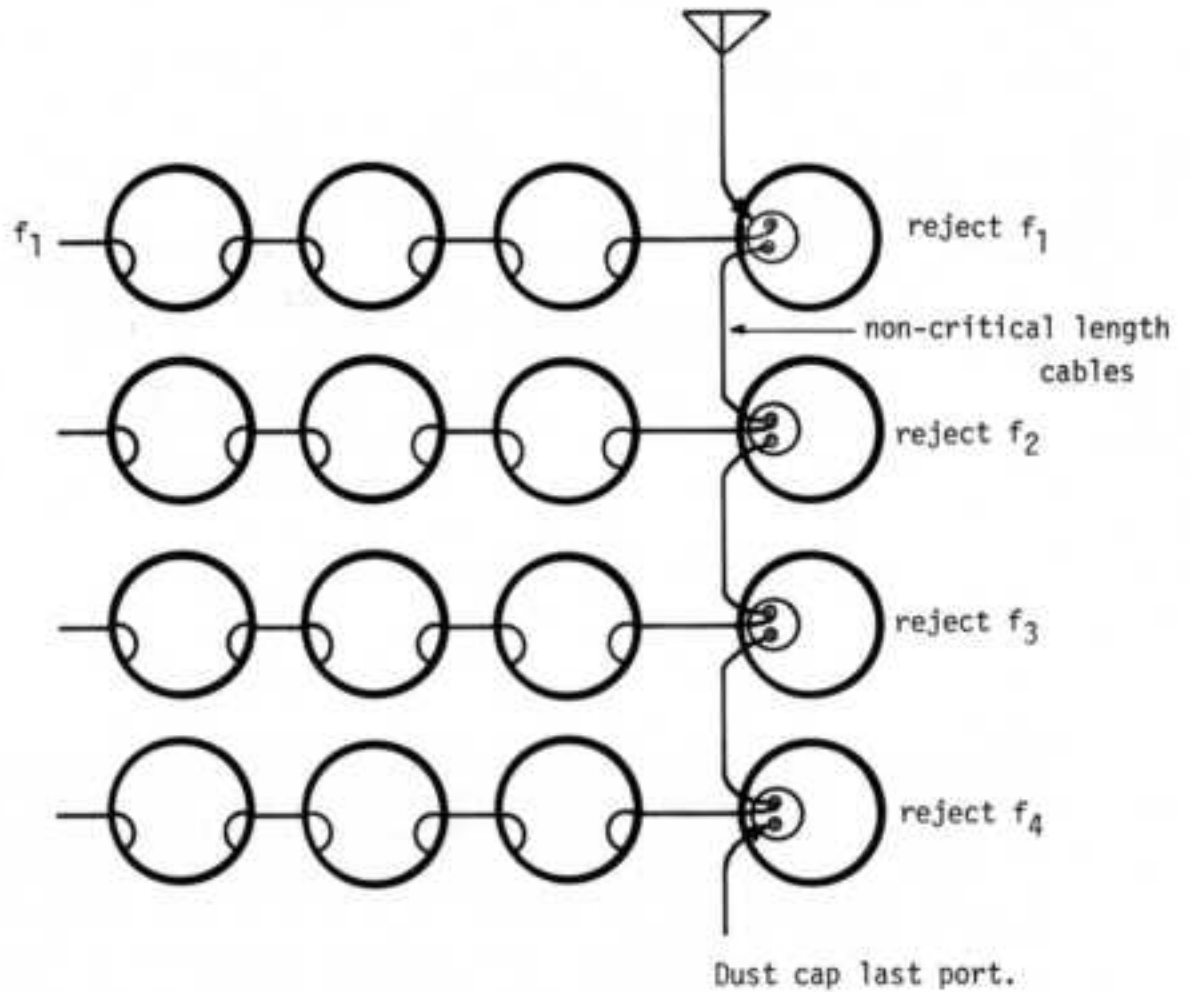

Subsequent channels may be inserted in any position in the existing chain.

MOST ADVANCED EXPANDABLE MULTICOUPLER DESIGN

V. T-passtm Expandable Cavity Multicoupler (TX RX SYSTEMS PATENT NO.4249147)

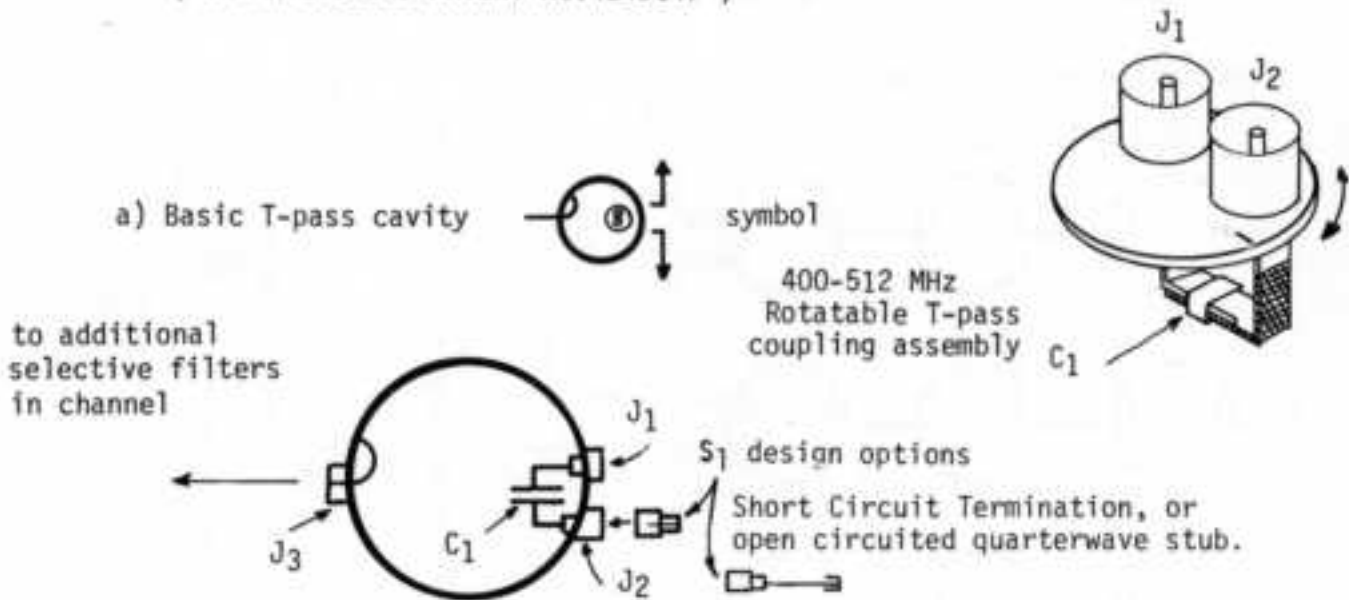

1. J_3 is a standard rotatable bandpass Loop assembly.
2. J_1 and J_2 are antenna thru-line connectors of rotatable T-pass coupling assembly.
3. C_1 is a capacitor whose value is adjusted to be broadly resonant with the loop inductance, such that a 50 ohm transmission line is formed between J_1 and J_2 . This characteristic is present at all system frequencies, except at the resonant frequency of the cavity, where the 50 ohm transmission line is changed, in function, by stub S_1
4. S_1 is usually a short circuit termination for broadband operation. In either form, physical short or stub, S_1 places an RF short circuit across a plane, approximately coincident with the surface of the Loop Assembly. The T-Pass assembly now functions as an ordinary bandpass coupling loop.
5. When the cavity is tuned to resonance, and an RF short circuit is presented across the J_2 connector, the T-pass cavity functions as an ordinary bandpass filter between J_1 and J_3 . The T-pass coupling assembly is rotated, in conjunction with the standard bandpass loop, and calibrated for 0.5 and 1.0 db loss settings. Occasionally, other settings, as 1.5db, 2.0db, and 3.0db may also be calibrated. A relative calibration index label (0-20) is used on T-pass assemblies, with 10 as index for 1.0 db loss on all assemblies.
6. A "tuned" antenna thru-line is used to interconnect multiple T-pass channels.

TOP VIEW OF CAVITY

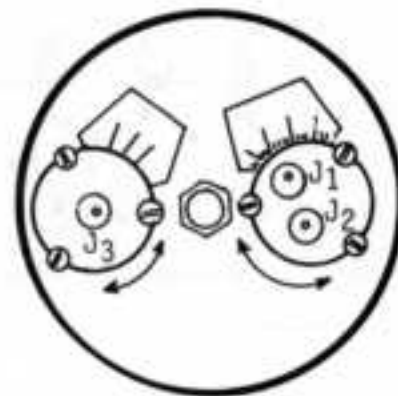

MOST ADVANCED EXPANDABLE MULTICOUPLER DESIGN (CONT'D)

V. T-passtm Expandable Cavity Multicoupler

b) Antenna ThruLine interconnection principle

added selectivity as required

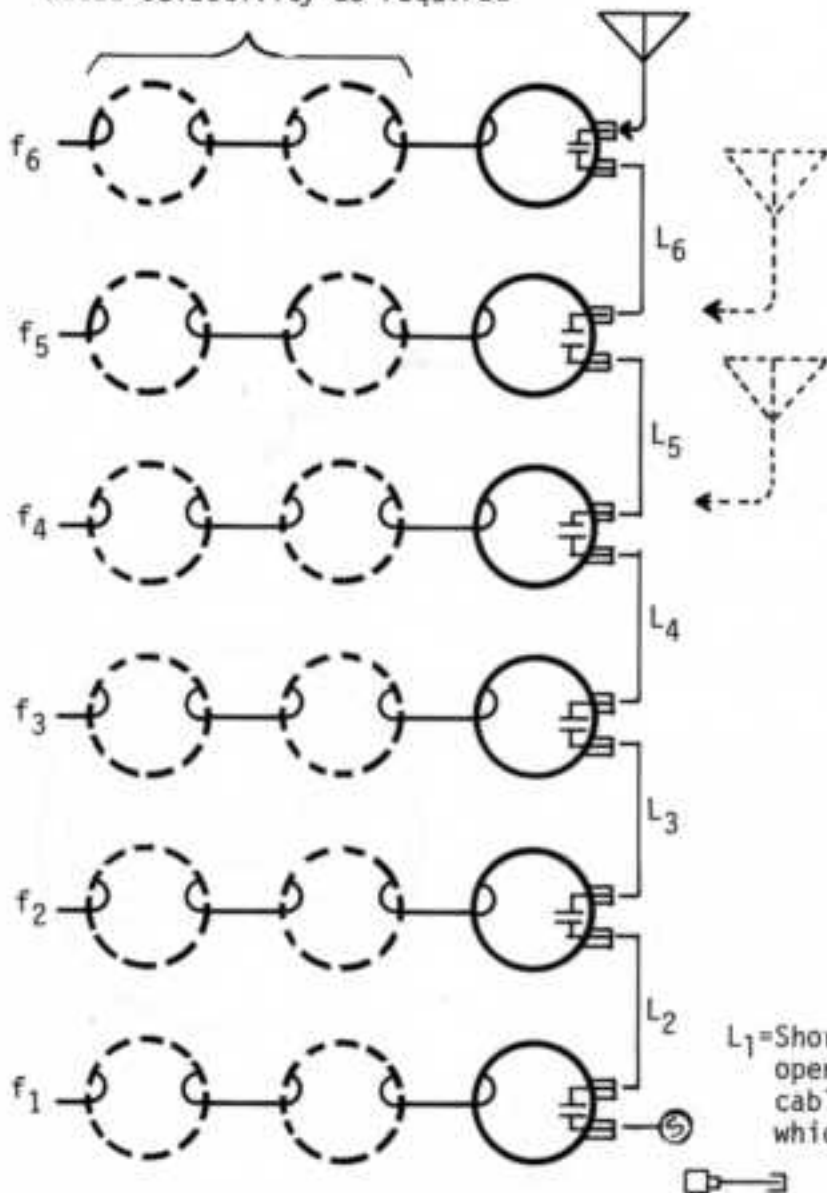

Channels generally follow frequency pattern high to low

Length of ThruLine cables above any channel (toward antenna) have no effect on that channel except pure cable loss. A bridging loss also occurs across adjacent channel T-pass assemblies, which is a function of channel separation. A 'normalized Bridging Loss Chart' is available for estimating this loss, and requires a selectivity curve for each channel for obtaining total bridging loss. Total channel loss is the sum of raw channel loss, bridging losses, and dead ThruLine cable loss.

L_1 = Short circuit termination or open circuited stub. ThruLine cable cutting charts will indicate which form of L_1 to use.

- L_1 = odd multiple of quarterwaves at f_1
 - $L_1 + L_2$ = odd multiple of quarterwaves at f_2
 - $L_1 + L_2 + L_3$ = odd multiple of quarterwaves at f_3
 - $L_1 + L_2 + L_3 + L_4$ = odd multiple of quarterwaves at f_4
- and so on.